

TABLE 1: ELECTRICAL SPECIFICATIONS AT 25 °C
 SWITCHING TRANSFORMER DESIGNED FOR USE WITH POWER INTEGRATIONS
 PWR-TOP204YAI. REFER TO APPLICATION CIRCUIT OF FIGURE 3.

PARAMETER	SPEC LIMITS			UNITS
	MIN.	TYP.	MAX.	
PRIMARY INDUCTANCE (2-1) VOLTAGE = 0.250Vrms FREQUENCY = 100 KHZ	320	350	380	μHY
URNS RATIO'S: SEC (12-11) : PRIMARY (2-1) AUX #1A (9-8) : PRIMARY (2-1) AUX #1B (8-7) : PRIMARY (2-1) BIAS (5-6) : PRIMARY (2-1)	-----	1: 3.44 1: 4.43 1: 10.33 1: 4.43	-----	± 4% ± 4% ± 4% ± 4%
HIPOT: PRIMARY, BIAS & AUX'S TO SEC PRIMARY & BIAS TO AUX'S	3750 3750	----- -----	----- -----	Vrms Vrms
APP CIRCUIT PARAMETERS: ⁽¹⁾ AC LINE VOLTAGE 47/400 Hz OUTPUT VOLTAGE-AUX #1B ⁽²⁾ OUTPUT CURRENT-AUX #1B OUTPUT VOLTAGE-AUX #1A OUTPUT CURRENT-AUX #1A OUTPUT VOLTAGE-SEC ⁽³⁾ OUTPUT CURRENT-SEC LINE REGULATION (85 TO 135Vac) LOAD REGULATION 0-100% RIPPLE	85 0.05 0.01 0.01 ----- ----- -----	----- +5.0 ----- +15.0 ----- +15.0 ----- 0.50 0.50 50.0	265 1.2 .200 .200 ----- ----- -----	Vac Vdc Amps Vdc Amps Vdc Amps ±% ±% ±mV

- (1) REFER TO APPLICATION CIRCUIT OF FIGURE 3.
 (2) AUX #1B IS THE MAIN FEEDBACK CONTROL WINDING.
 (3) SECONDARY VOLTAGE IS OBTAINED VIA A LINEAR REGULATOR.

FIGURE 2: PHYSICAL DIMENSIONS mm (INCHES)

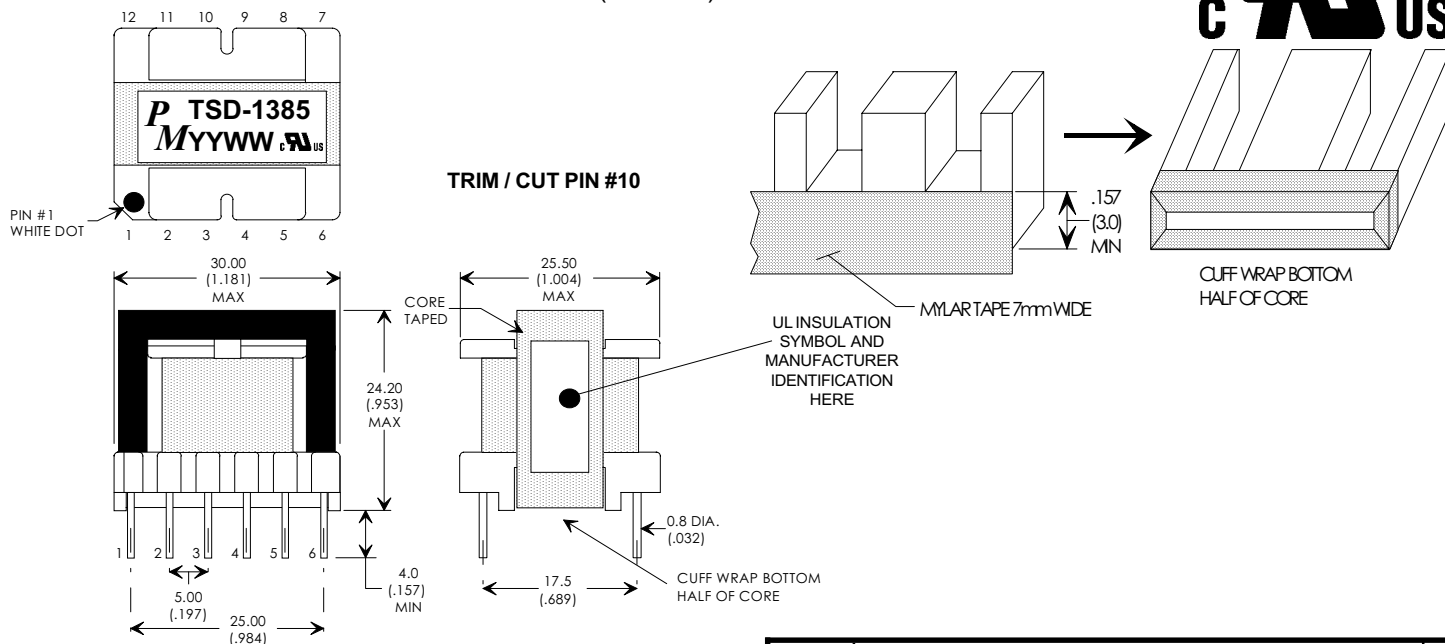
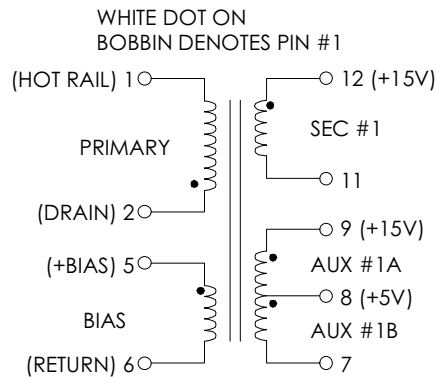
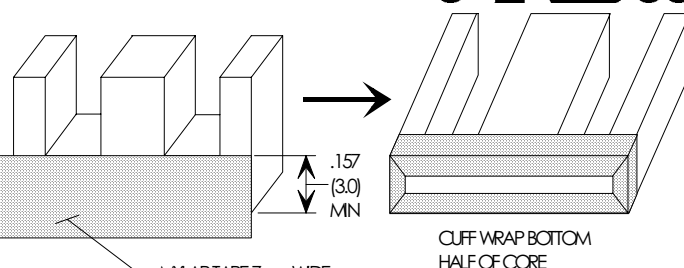

FIGURE 1: SCHEMATIC DIAGRAM



**TRIPLE INSULATION ON AUX'S AND SECONDARY
 ISOLATION BETWEEN AUX'S AND SECONDARY**

- NOTE1:**
REINFORCED INSULATION SYSTEM, UL 1950, IEC950, CSA-950:
 A) ALL MATERIALS MEET "UL", "CSA" & "IEC" REQUIREMENTS
 B) UL1950, CSA-950, IEC742/950 & VDE.
 C) TRIPLE BASIC INSULATED SECONDARY.
 D) DESIGNED TO MEET ≥6.2mm CREEPAGE REQUIREMENTS.
 E) VARNISH FINISHED ASSEMBLY.
 F) UL 1950 & CSA-950 CERTIFIED: FILE #E162344.
 G) UL CLASS (B) 130 INSULATION SYSTEM PM130-R1,
 PM130-H1, PM130-H1A (UL FILE #E177139) OR ANY UL
 AUTHORIZED CLASS (B) INSULATION SYSTEM.



REV.	DESCRIPTION OF CHANGES	BY
06/08/99	REDESIGN TO MEET CUSTOMER NEW REQUIREMENT	PP
06/29/99	ADD CUFF WRAP AND NOTE 1	PP
07/21/99	REDESIGN TO 5,15 & 15 Vdc	PP
09/02/99	CHANGE # TURNS OF SEC#1 FROM 10T TO 9T	PP
09/21/99	UPDATE TO UL CLASS (B) 130 INSULATION SYSTEM	MD
01/05/00	UPDATE TO UL RECOGNIZED CONSTRUCTION #E162344	MD
02/03/00	CORRECT TURN RATIO TEST	PP

EE, EI28/11, 12-PIN VERTICAL BOBBIN



UNLESS OTHERWISE SPECIFIED
 DIMENSIONS ARE IN MM
 DIMENSIONAL TOLERANCES ARE:
 DECIMALS ANGLES
 .X ± .25 ±0° 30'
 .XX ± .15
 DO NOT SCALE DRAWING

TRANSFORMER CONTROL DRAWING

PREMIER P/N: TSD-1385	REVISION: 02/03/00
ENGR: PETER PHAM	REF: PWR-TOP204
SCALE: NONE	SHEET: 1 OF 6

APPLICATION NOTES

Premier Magnetics' TSD-1385 Switch Mode Transformer was designed for use with Power Integrations, Inc. PWR-TOP204YA1 three terminal off-line PWM switching regulator in the Flyback Buck-Boost circuit configuration. The PWR-TOPXXX series from Power Integrations, Inc. are self contained 100KHz three terminal voltage controlled PWM switching regulators. This series contains all necessary functions for an off-line switched mode control DC power source. These switching regulators provide a very simple solution to off-line designs. The inductors and transformer used with the PWR-TOPXXX are critical to the performance of the circuit. They define the overall efficiency, output power and overall physical size.

Below is a universal input (85Vac to 265Vac) input high precision 15 watt application circuit utilizing Power Integrations PWR-TOP204 switching regulator. This circuit provides three precision outputs. The "MAIN" output of Aux #1B is optically fed back to the PWR-TOP204 controller to close the voltage feedback loop. Secondary #1 is fed into a linear regulator to provide a high precision output. The component values listed are intended for reference purposes only.

FIGURE 3: TYPICAL APPLICATION CIRCUIT

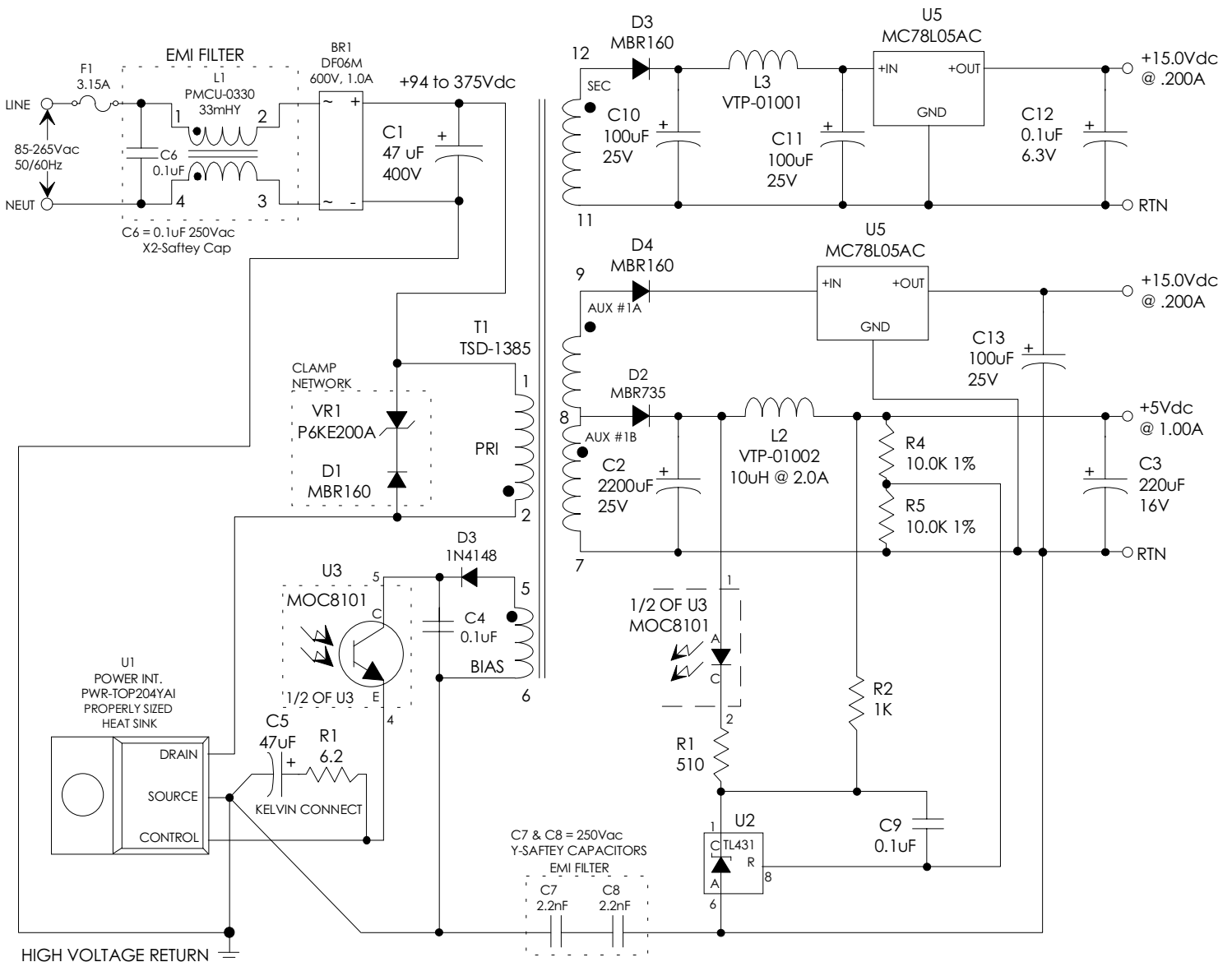

UNLESS OTHERWISE SPECIFIED
DIMENSIONS ARE IN MM
DIMENSIONAL TOLERANCES ARE:
DECIMALS ANGLES
.X ± .25 ±0° 30'
.XX ± .15
DO NOT SCALE DRAWING

TRANSFORMER CONTROL DRAWING	
PREMIER P/N: TSD-1385	REVISION: 02/03/00
ENGR: PETER PHAM	REF: PWR-TOP204
SCALE: NONE	SHEET: 2 OF 6